



**COMPRESSION TOOLING BROCHURE**

# WORLD OF ROTEK

---



## TABLE OF CONTENT

---

Section I	<b>About Us</b>	04
Section II	<b>About Tablet Tools</b>	08
Section III	<b>Tool Steel</b>	10
Section IV	<b>Tool Coat</b>	14
Section V	<b>Tool Combos</b>	19
Section VI	<b>Tool Care</b>	30

---

## ABOUT US

“Complete solution for  
all your **Tableting Needs.**”

**ROTEK PHARMA TECHNOLOGIES** was founded by a team of tooling experts in 1987, with an experience of over three decades in Tooling Technology.

### WHO WE ARE

- Tablet Tooling manufacturer involved into manufacturing & development of precision component.
- We are seasoned and experienced.
- Troubleshooting experts.
- Trusted and relied by over 250 clients worldwide.
- Providing services across 5 continents.

### WHAT WE DO

We manufacture Steel Bars into Precision Tools that are used for Tablet Compression. We are involved in providing solutions towards any Tableting constraint with sales and service support in over 27 countries worldwide. We also provide complete solution for all your Tableting needs. We are the creators of the engineering marvel “WORLD’S MOST ACCURATE TABLETING TOOL”.



**“We are mainly engaged in Design, Development, Manufacturing and supply of Quality Tablet Tooling's & its Accessories”**

We have the expertise and facilities to meet the growing demand of the tableting industry for standard / customized tooling's for a range of application. Our wide range of products include ***A to Z solution for all your tableting needs.*** Our commitment towards developing ground-breaking solutions through R&D in areas such as ***metallurgy, punch coating, boosting productivity*** (by our multi tip solutions) and Quality Assurance Measures which has been successfully adopted by customers worldwide.

**“We believe that every penny spent in research and development is a penny well spent”**

We have been supplying our tooling's to various sectors like Pharmaceutical, Nutraceutical, Confectionery, Veterinary, Cosmetic & Ceramic Industries by marketing it in both domestic as well as international market.

At ROTEK PHARMA TECHNOLOGIES we not only manufacture tablet tooling's of unparalleled quality, but also provide support equipment to help maintain tablet quality. Our headquarters is strategically located in one of the finest progressive industrial societies. ROTEK PHARMA TECHNOLOGIES campus includes Administration, Manufacturing, Testing, Training and R&D facilities specifically designed to convey our customers about our Development, Growth & Reliability.

## LEADERSHIP



### **VIJAY BHAYANI** **Chairman**

He is the Pioneer of this multi scale organization, he is an Engineer who started his career in year 1980 as technical support engineer in a machine spare manufacturing company. Keeping his vision & admirations to be an entrepreneur started his own enterprise as TECHNIC ENGINEERING WORKS in the year 1987 which is today known as ROTEK PHARMA TECHNOLOGIES. He is a person of Knowledge, Inspiration & Trust, his principles and ideas have driven ROTEK to be a Trusted & Reliable organisation.

“He is the soul of ROTEK “.

### **ANAND BHAYANI** **Managing Director**

He is a Tooling Expert with his vision to develop the “Best Of What We Do “ has made us a company that works on a no compromise policy for which has given our Brand a Seal of Trust. It reflects in the companies tag line “Tablet Tooling’s That Deliver Trust ” and because of his technical expertise we are today the Best Troubleshooting Experts. His belief in customer satisfaction, has helped us create customized solutions for almost every tableting issue and because of which we have multiplied our Customer & Production base. “ He is the Pillar of ROTEK ”



## TEAM



**ROTEK** has a history that stats **3 decades** of it journey which is the journey of people who have been there with the organisation from the very beginning and share a bond that makes the **ROTEK family** in which we have Turners, Grinders, Buffers, Craftsman & Executives who have started their carrier with ROTEK and are still a undetached part of the organisation. As we know it's never a one man's effort to convert success into reality, it is the Team that has made the vision true and without the support of a Team it would never had been a reality. So we at ROTEK believe in the people who have made us and give them the complete credit of our success. Also we at ROTEK believe in our Team and keeping their efforts in mind we have developed a friendly atmosphere to work in, as we strongly believe in employee satisfaction and only a satisfied employee can make a happy customer. We are a Organised Team.

The Team at ROTEK structures as under the Leadership of MR. VIJAY BHAYANI (Chairman) with him **3 Directors** each with their own teams as MR. ANAND BHAYANI (MD) managing a Team of **60+ members** along side MR. SAGAR BAHAYANI (COO) managing the Production Team of 45+ members joined by MR. DHIRAJ SINGH RATHORE (MARKETING & SALES DIRECTOR) managing a Team of 12+ members and many more who play a major role in the organisation.

At ROTEK we have created a environment to **Work, Play & Cherish** the moments spent in the organisation, where to motivate The Team we arrange weekly activities like Games, Movies, Cultural Events and Events for CSR with this we keep up the Team spirit at par and give them a reason to be social with a good cause.



**" WHEN QUALITY IS THE REQUIREMENT,  
WE ARE THE 1<sup>ST</sup> CHOICE OF INDIA. "**

**WE MANUFACTURE TOOLINGS FOR:**



**& many more catering the industry.**

Tablet Compression Tooling's are in the existence from more than a century now and as being the only source to form solid dose of medication through compression the industry has seen many changes and advancements with the use of Special Purpose Tool Steels to finding new ways on resolving the general & critical Tableting issues with Advanced Coating Solutions to Introducing Multiple Tip for the Tooling to improvise & boost productivity which has been very Revolutionary for the past couple of decades in which we have been a part of the journey and are proud of the same.

With the introduction of new and robust Technical Advancements alongside the implementation of Automation we have been aiming all the possibilities to make things better and relieving for the user, giving them peace of mind and ability to focus better on other sections of work.

Keeping this user satisfaction as our priority we **ROTEK PHARMA TECHNOLOGIES** started our **manufacturing facility in 1987** and since have always catered the industry's growing demands and finding newer ways to help make things better for the end user, which has given us a good market presence and a huge list of happy customers worldwide, by keeping the focus straight on what we started it with we are **always learning & innovating.**

The categories we make tooling's for is undefined as we are equipped to manufacture any customized tooling required by the client to cater their needs, but here are a few commonly made tooling types :

- **EURO STANDARD TOOLING**
- **TSM STANDARD TOOLING**
- **FETTE TOOLING including SEGMENT DIES**
- **KILIAN TOOLING**
- **JAPANESE STANDARD TOOLING**
- **BOLUS TYPE TOOLS**
- **MULTI TIP TYPE TOOLING CUP TYPE**
- **MULTI TIP TYPE TOOLING MONO BLOCK TYPE**
- **MICRO TIP TYPE TOOLS**
- **SNAP TAB TYPE TOOLS**
- **3D TIP TYPE TOOLS**



# TOOL STEEL

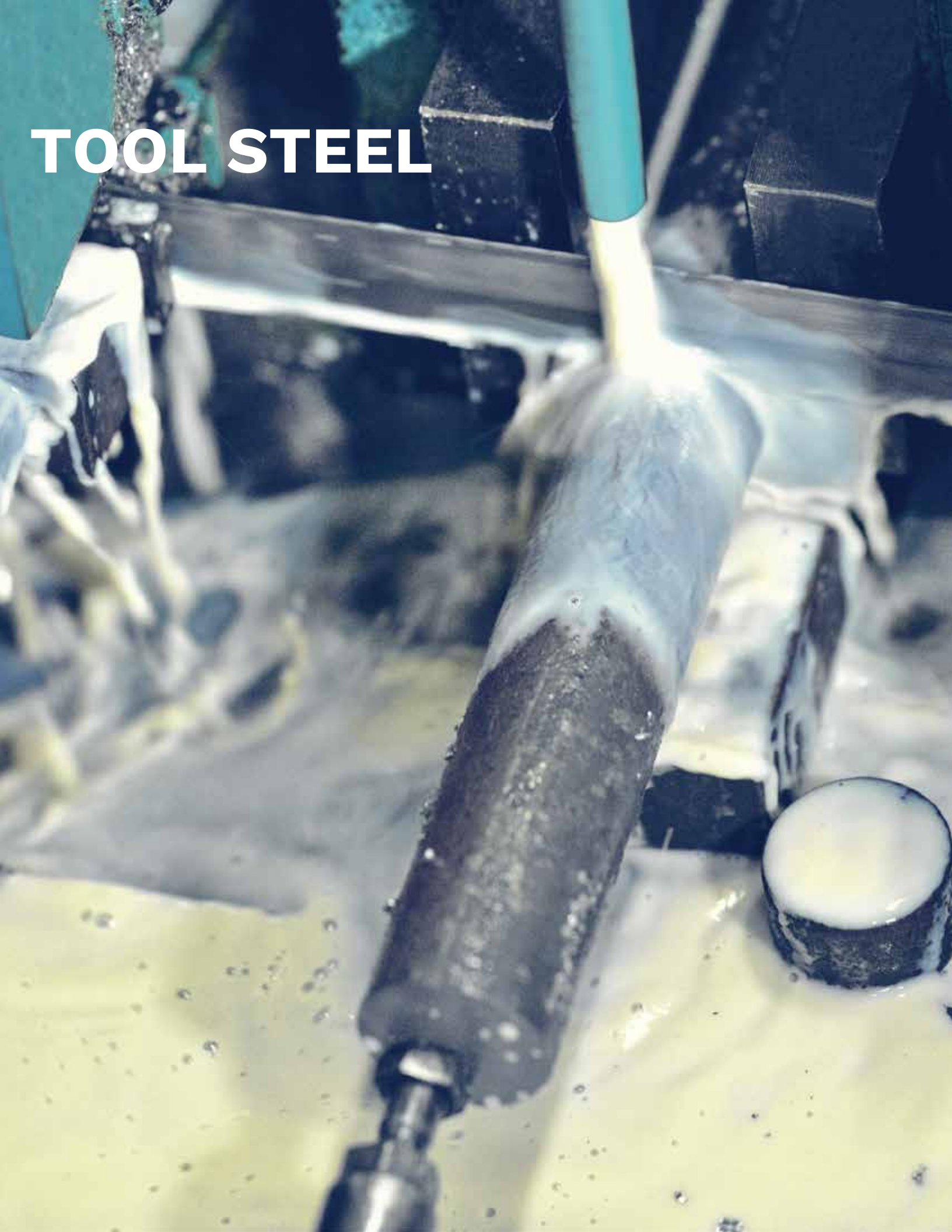

For tool steel - toughness, resistance to wear & corrosion, strength & resistance to distortion & warping during heat treatment are its most important properties. These properties are the condition under which it is manufactured. For purpose of comparison, the steels used to manufacture tablet press tooling have been categorised below:



## **01 STEEL**

It is a General Purpose Steel which is a Oil Hardened Non Shrinking Steel which has High Hardenability and is commonly used for Blanking & Stamping Punches.

## **S7 STEEL**

Is a tool steel grade with exceptional impact resistance plus the highest hardenability of shock resisting grade of Tool Steel due to which is commonly used in Tablet Compression Punches for its heavy load bearing capacity.

## **D3 STEEL**

Is a Hot Die Steel and comes under the Category of High Carbon High Chromium (H.C.H.C.) Steel which has Great Resistance to Wear due to the percentage of Chromium in its structure for which it is also the most preferred choice for Tableting Dies.

## **D2 STEEL**

It comes under High Carbon High Chromium (H.C.H.C.) Steel category which also has Excellent Wear Resistance & Abrasion Resistance and so is generally used for Abrasive Tablet Compression.

## **A2 STEEL**

Is a Cold work Steel and is a Air Hardening Steel which provides High Hardness with good dimensional stability which also averages better Wear Resistance.

## **S1 STEEL**

Is a Cold work Steel which has Tungsten in its Elements due to which it has Greater Toughness and Impact Resistance also can obtain High Hardness.

## **408 STEEL**

Is a Stainless Steel which is a Ferritic Steel that offers good mechanical properties which is Resistant to Corrosion and prevents rust corrosion cracking.

## **440C STEEL**

Is a Stainless Steel type with High Carbon and High Chromium percentage of Elements which also has Excellent Hardenability and can go upto 60 HRC max. This category of Steel is used to Manufacture Small Tips for Multi Tip Tooling's.

## SP10 STEEL

Is a primarily a Oil Hardening Grade Steel which was developed for Better Resistance to Shock that has Good Elemental combination of Manganese-Silicon-Molybdenum.

## K340 STEEL

Is a Premium Cold work Steel which has High Yield Strength and good Toughness properties which is suitable for Chipping & Premature Wear issues also has Excellent Compressive strength.

## M340 STEEL

It is a Premium Steel with Chromium content of upto 16% to 18% which helps in obtaining least Ra value on the surface giving the surface a mirror finish which make it very less Coefficient to friction.

## N690 STEEL

Is a Premium Steel with Chromium content similar to the PK5 Steel with the addition of Cobalt in it which bonds the molecular structure uniformly giving it Greater Surface finish and Longer Durability.





## CHEMICAL COMPOSITION OF TOOL STEELS

CHEMICAL ELEMENT	PERCENTAGE OF CHEMICAL ELEMENTS											
	O1	S7	D3	D2	A2	S1	408	440C	SP10	K340	M340	N690
<b>C</b> CARBON	0.85-1.00	0.45-0.55	2.00-2.35	1.40-1.60	0.95-1.05	0.40-0.55	0.40-0.55	0.95-1.20	0.95-1.40	0.90-1.20	0.40-0.60	0.90-1.20
<b>Mn</b> MANGANESE	1.00-1.40	0.20-0.80	0.00-0.60	0.00-0.60	0.00-1.00	0.10-0.40	0.40-0.60	0.00-1.00	0.10-0.70	0.20-0.50	0.20-0.50	0.20-0.50
<b>Si</b> SILICON	0.10-0.50	0.20-1.00	0.00-0.60	0.00-0.60	0.00-0.50	0.15-1.20	0.20-0.50	0.00-1.00	0.10-0.60	0.60-1.00	0.20-0.50	0.20-0.50
<b>Cr</b> CHROMIUM	0.40-0.70	3.00-3.50	11.0-13.5	11.0-13.0	4.75-5.50	1.00-1.80	0.60-0.80	16.0-18.0	10.0-14.0	7.00-9.00	16.0-18.0	16.0-18.0
<b>V</b> VANADIUM	0.00-0.30	0.20-0.35	0.00-1.00	0.00-1.10	0.15-0.50	0.15-0.30			0.00-0.80	0.15-0.50	0.00-0.20	0.00-0.20
<b>W</b> TUNGSTEN	0.10-0.60		0.00-1.00			1.50-3.00						
<b>Mo</b> MOLYBDNEUM		1.30-1.80		0.70-1.20	0.90-1.40	0.00-0.50		0.00-0.75	0.80-1.50	1.80-2.20	0.90-1.10	0.90-1.10
<b>Ni</b> NICKEL	0.00-0.30		0.00-0.30		0.00-0.30	0.00-0.30	1.50-3.00					
<b>Cu</b> COPPER		0.00-0.25	0.00-0.25		0.00-0.25	0.00-0.25						
<b>Co</b> COBALT				0.00-1.00								1.20-1.60

# TOOL COAT



Based on the product nature such as - abrasive, corrosive, sticky etc.

We at **ROTEK PHARMA TECHNOLOGIES** recommend various types of coating. As described below :

## **HCP**

A Type of CVD coating which is highly reflective and resistant to Corrosion & Wear also has Very less Coefficient to friction resulting in smoother Compression & Ejection of Tablet, **also this coating comes as a default with ROTTEK Compression Punches.**

## **ENI**

A two tone silver goldenish coating which is obtained by deposition of Nickel alloy into the metal surface by a bath and not by electrodes or external electrical charges which allows even surface deposition resulting in a Very Smooth Surface Finish.

## **HCP+**

A uniquely developed coating which is PVD Superior Hard-Chromium Coating which has a very homogeneous structure along with low density of pores with a good Non-Stick property.

## **TIN**

Is a Golden coating which is Very Hard and due to which it works great against Wear resistance which is also used for both Punch & Die to protect it from Wear & Corrosion.

## **CRN**

It is a Extremely Hard and inert coating with upto 2X harder then Hard Chrome which performs well in Corrosive environment and in sliding Wear applications. It also has Low Residual Stress and is Low Coefficient to friction.

## **CRN+**

Is a Silver Black coating which is Hard and is a Double layer of Chromium Nitride coating on the Punch surface which results in a almost pore free surface which helps in Compression of Abrasive Tablets making it more durable and sustainable in such environment.

## **CRX**

Is a Greyish coating which is specially developed to also work with Abrasion and Sticking at the same time which is also a combination coating which has triple layer protection to give the best results for Sticking & Wear related issues.

## **CRX+**

Is a Dark Grey coating which along with 2 layers of coating has a 3rd Thick & Dense layer of surface coat which helps further in dealing with Abrasion, Sticking, Wear & Galling also adding up the durability of the Punch with increased service life.

## **SPN**

Is a Silver Grey coating which is the Best performer against Heavy Sticking & Picking issues due to its Nano structure the surface on which it is applied gets a pore free surface finish and provides a very smooth surface area which is unmatched by any other surface coating.

## **SPN+**

Is a Silver Grey coating which is dense thick layer of an already super fine coating which helps in Heavy Sticky Tableting conditions due to its Nano structure it gives the Best surface finish which is uncomparable with any other surface coating.

## **MLY**

A Mild Silver coating which is a combination coating which is a two layer coating which has a additional surface with anti stick properties which further reduces the effect of formulation sticking on the Punch Face.

## **DLC**

Is called Diamond Like Carbon coating which is Black and is a Nano Composite coating which has a unique property of natural diamond low friction, high hardness and high corrosion resistance which is perfectly suited for most extreme tableting conditions.

## **ZLD**

Is a Hard Coat which has a strong bond with the component and is longer lasting due to its deposition strength which happens to be really strong due to its high temperature deposition which ensures to be the Best Bond with deposition surface.

## **RCOAT**

It is a coat on the Punch Tip surface that mimics a Teflon like surface smoothness to provide the best non stick properties that results in a surface which is dense and ultra smooth, also it has a surface that has the maximum lubricity.

## **ELDO**

Is a coat that can be done on both Punch & Die which works well on Abrasion and protects through wear. It is both Smooth and Hard so deals better with the products that demand Higher Compression Force and are Abrasive in nature.

## **CX1**

Is a Tungsten based coating which is less conductive and has a smoothness that is unmatched which is almost like ceramic surface. It is Black in color and the combination of Extra Smooth to High Resistance make is our preferred choice for extreme Tableting issues.





**NEW WORLDS  
BETTER TOOLS**

The pharmaceutical & Healthcare product manufacturing industry has been at it's Best in the recent period of time, observing a huge growth in the development of New Products & Molecules which without the right type of equipment's would have not had been possible, so as the industry grows all the relative factors play a major role in the same, on which we being in the industry from the past 3 decades have contributed a lot towards our role, with the introduction of PRECI TOOL “ The World's Most Accurate Tableting Tool ” along with the introduction of “ NURO TOOL” and also to introduce the “ Express Tool ” with the shortest delivery lead time, all this to support the growth of the Medical Age, as we know with every new development comes New difficulties and New possibilities we at ROTEK PHARMA TECHNOLOGIES have taken over every challenge that came our way to becoming the most Reliable Tooling Manufacturer.

## TOOL COMBOS

Our Top 10 Tool Combinations is all you need

**With this we would like to have an opportunity to introduce:**

- **PRECI TOOL** – THE WORLDS MOST ACCURATE TABLETING TOOL.
- **NURO TOOL** – THE TOUGH TOOL.
- **PRIMO TOOL** – THE PRIME TOOL.
- **STAR TOOL** – THE TABLETING STAR.
- **EXPRESS TOOL** – TOOLING THAT DELIVER SMILE.
- **DURO TOOL** – THE LONG LIFE TOOL.
- **ULTRA TOOL** – THE ULTRA SMOOTH TOOL.
- **ECO TOOL** – THE POCKET FRIENDLY TOOL.
- **UNIVERSAL TOOL** – THE GLOBAL TOOL.
- **SIP TOOL** – THE PRO TOOL.



## NURO TOOL - THE TOUGH TOOL.

With the Introduction of NURO TOOL “ THE TOUGH TOOL ” , when we say it we mean it, as there have been a demand of Tool's that last long for a wide range of benefits we took a step in managing to provide a ease of choice for our customers when there are a wide range of choices to make in deciding right Tools for your Tableting needs we thought to standardize one for you which will be Extra Strong, Extra Durable & Extra Lasting then your Current Tableting Tool and also which should provide an Extra Saving, with keeping all of this in mind we developed NURO TOOL combining our Best Tool Steels, Coatings & Process we would like to have an opportunity to introduce NURO TOOL for the Tableting Industry.

**Benefits** : With the NURO TOOL we guarantee a Tool Life that will exceed your expectations which is a great step forward in terms of CPC (Cost per Component) and also Tablet Quality as when you choose a Tool that Lasts longer than your current Tableting Tool you are sure to have a Better Tablet Quality for Longer Life Cycle and also when it is a Pocket Friendly solution you are sure to save a lot in the longer run.

**Eligibility** : The NURO TOOL is designed to suite all your Tablet Compression needs which can take on any Formulation that comes it's way. With this you can compress any Corrosive, Abrasive or Regular Product and see it perform the Best towards whatever comes across.

**Suggestion** : We recommend this when you have demands of Savings, Performance & Durability. With the NURO TOOL your investment will give you a definite return in a big way during the long run as with this you not only improve the Tablet Quality with improved Tool Life but also lower the Cost Per Component of your product, this is a Product developed with the Experiences and Expertise of our Tooling Knowledge which will become your preferred choice once experienced.





## PRIMO TOOL - THE PRIME TOOL

With the Introduction of PRIMO TOOL we have created a tool that will serve as a Primary Tool for most of your resolution based requirements. On this we have implemented advanced process to Super Finish the Tip Surface Smoothness the drag caused while compression along with this we have also introduced the Tool to a Special Treatment called MFT (Multi Flow Technology) which further reduces the coefficient to friction on the Punch Tip Surface and providing us with a Tool that is Smoother than Smooth and serves the purpose for what it has been developed.

**Benefits :** With PRIMO TOOL our vision was to develop a Tool for our Customers which will be a first choice towards a trouble free Tablet Compression, which turns out to be one of the Best performers towards Smearing, Sticking, Picking & Edging issues. With the introduction of this we have initiated towards a product that a the Maximum scope towards resolving the everyday Compression issues face at the production end. Also this Combination of Process & Flow Technology is a best Fit in Terms of Troubleshooting, Price & Durability which is unmatched by any other.

**Eligibility :** The PRIMO TOOL is an introduction that suites most of the Products excluding some which are Hard to Compress & Abrasive which is due to its above than normal Surface Smoothness which if introduced to a Abrasive or Hard to Compress products it will lead to deterioration of its Tip Surface Finish which will make it a non purposeful investment, apart from some very few products it is suitable for most of the products at a Pharmaceutical Production site.

**Suggestion :** Our recommendation on PRIMO TOOL is for all or most of your Tableting Products that if replaced with PRIMO will enhance your Product Finish, will be Long Lasting, will be a resolution for most of the issues and will Turn out to be a Great Cost Saver. Adding all this together makes a product that is almost the PRIMARY product for all your Tableting needs. PRIMO for ROTTEK is what are Wings for a Flight and we believe our product line to be incomplete without PRIMO.

## STAR TOOL - THE TABLETING STAR.

With the Introduction of STAR TOOL we have created a STAR IN TOOLS that will shine brighter. On this we have combined our process knowledge and customer feedbacks which have inspired us to develop a Tool that is Smoother and Stronger at the same time which makes for a combination that is rear and refined. This is Best combination Tooling which comprises of ESR processed Tool Steel along with the Combination of Coatings applied on the same making it the Best Tool of choice.

**Benefits :** With STAR TOOL we have made an effort to give our customers a hassle free compression experience which results in Great Non Stick performance for all the products related to sticking, picking issues. With this you get a product that is Smoother than your Standard Non Stick Tool which is because of the Process involved in the making of the same which is Highly Precise, Skill oriented and is developed with the help of expertise & workmanship of our efficient work force catering the same from past 3 decades.

**Eligibility :** The STAR TOOL is designed to suite the Troublesome, Sticky & Picky formulation which is now a common phase in every Tableting facility. With this you can compress all such products with difficulty making it at easy after implementing the Star Tool package. Also we claim it to be the STAR of our line up due to its ability to resolve the issues & convince the user of its capabilities.

**Suggestion :** We recommend this when you have the need to resolve an Formulation Sticking, Picking issues on the Tablet Face due to the Punch Face absorbing the same. With the STAR TOOL the user can be at easy when dealing with such Formulation as we have them covered for the worry some issues to be faced, hereby giving them the freedom to choose what is required for the product rather than what it will face in the compression.





## EXPRESS TOOL - TOOLING THAT DELIVER SMILE.

With the Introduction of EXPRESS TOOL “ Tooling That Deliver Smile “ we have created a supply system that makes sure your Tools arrive the site before Timeline giving you that extra confidence towards matching the desired production schedule. This is due to the synchronization of our in house production cycles we can prioritise your needs keeping us above the competition in terms of delivering a smile to our customers.

**Benefits :** With EXPRESS TOOL you can expect Quickest Delivery of your required Tooling Inventory which helps when you have a Tool provider that has your back when you are stuck in an unfortunate urgency of a kind which can give you sleepless nights. We claim it to be the Quickest Arriving Tool as when you opt for the feature we know it is a urgency which needs no compromise and undisputed delivery schedules for which we always deliver on commitments.

**Eligibility :** The EXPRESS TOOL is an optional feature that could be availed on any and every Compression Tooling manufactured by ROTEK which gives our customers peace of mind and can opt for it as and when required. Also this is a feature that adds proposition to our Product line which shows our dedication towards the elements we produce.

**Suggestion :** We recommend this when you have a rush on to producing Tablets before due date and also when there is an unexpected Error involving the Tablet Tooling’s resulting in delayed production and financial loses due to the same. We believe everything is incomplete with out this added feature in the line up which sets a ultimate high in terms of our orientation towards customer service.

## DURO TOOL - THE LONG LIFE TOOL.

With the Introduction of DURO TOOL “ THE LONG LIFE TOOL ” , when we claim it to be the Tool with a Life Longer than ever we have it concluded with Physical Trials resulting in unexpected Longevity of the Tool that is Highly Durable, Mamothely Strong & Unexpectedly Lasting that ends up being very economical when comparing it to the results and counts of Tablets produced. Keeping the thought of a Tool that can be of the Best Benefit to all we have developed this product with the combination of the Very Best in Tool Steel, Very Strong Coating & Process with all this combined the outcome is exceptional and it would be evident once under the compression cycle.

**Benefits** : With the DURO TOOL we claim the Tool life to exceed your expectations which will be a great leap towards the cost saving factor involved with the same when compared to the CPC (Cost per Component) also with which adds improvised Tablet Quality as and when you choose a Tool that Lasts Longer than the current Tableting Tool in use you are sure to save on many fronts that associate with the Tablet Compression.

**Eligibility** : The DURO TOOL is eligible for use on all kind of Tablet Compressions from Corrosive, Abrasive, Hard To Compress & Regular formulations with which you could expect it to perform the Best on matter what every comes in its way, as it is designed to suite all your Compression needs.

**Suggestion** : We recommend it for all your Tooling needs as and when Savings, Performance & Durability is required there is no looking further then the DURO TOOL. This will result in maximum return on your investment which will also Stand Tough on all the Rough Compression cycles that are difficult to compress. This is a winner that is the Best of the Best with Performance + Saving + Troubleshooting. So we would suggest to make DURO your new standard.



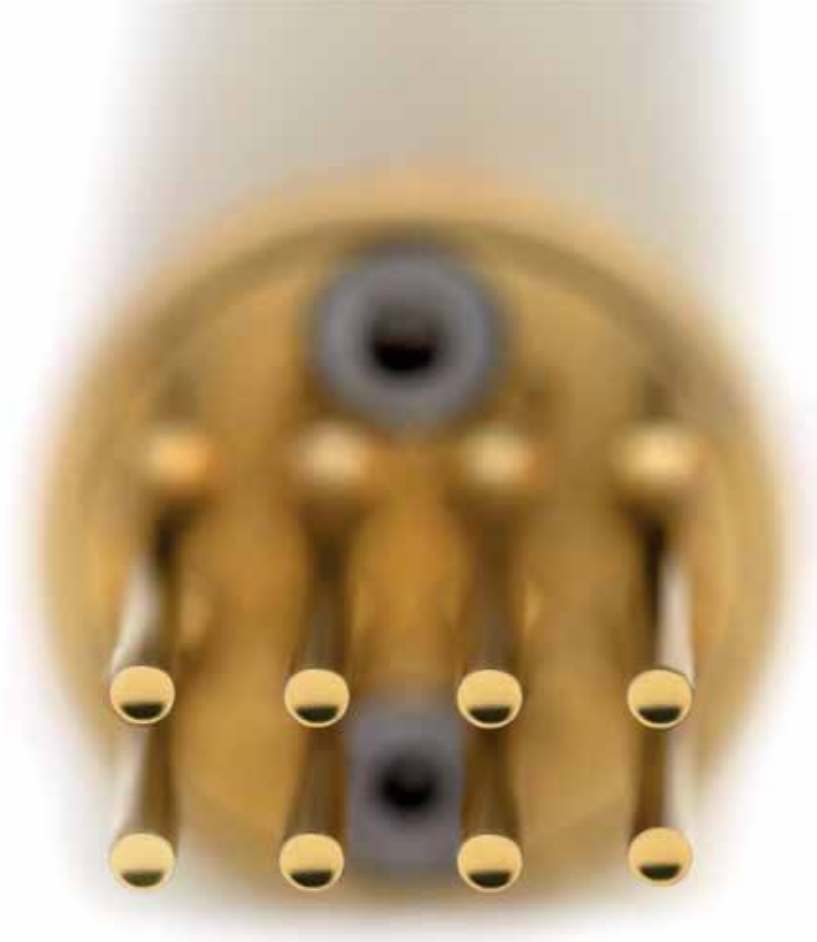

## **ULTRA TOOL - THE ULTRA SMOOTH TOOL.**

With the Introduction of ULTRA TOOL “ The Ultra Smooth Tool ” we have created a Tool that is Ultra in all terms & measures. With our expertise in Troubleshooting we have developed a Tool combination which is the Best example of Knowledge & Seeking as we faced more and more issues we learned more overcoming this we came up with a Ultra Solution for your Ultra Product which is giving you Ultra Tough Time. This Tools Tip Face is as Smooth as it can get to get you out of all the issues that are above normal.

**Benefits :** With ULTRA TOOL one can benefit big time over the Products that are Highly Sticky in nature and have to go through a regular cleaning & polishing cycle hampering the Productivity and also disturbing the next Compression Cycle. With this we have created a Smoother than ever surface which is almost pore free and is an outcome of years of Troubleshooting Experience & Highly Skilled and efficient Processing. Our product has also grown with age becoming a Mature Tool when it comes to handling difficult issues.

**Eligibility :** The ULTRA TOOL is developed to Troubleshoot Heavy Sticking issues which is observed in many Tableting formulations this days & is a every day hassle in every Tableting facility. With this you can be free of all the issues related to Sticky Formulations & free your time dedicated in resolving the same through formulative alterations. This will be a ultimate support towards all the complexes occurring.

**Suggestion :** We recommend this when the need is to resolve the unresolved that is while facing a situation that is not your normal occurring and is resulting in hard times for the Product & the Tool. We are confident with our ULTRA TOOL to give you the results that gives you the freedom to explore every possibility related to the formulation and changes to comply the end result. Also with this attempt we would like to prove the eligibility of our development that is a solution which has raised the Tooling Standard.

## ECO TOOL – THE POCKET FRIENDLY TOOL.

With the introduction of ECO TOOL as the name suggests a Tool that is pocket friendly not because of any compromises but because of the Equipment's & Fixtures used for producing the same. We at ROTEK PHARMA TECHNOLOGIES have a product to suit all your requirements from High Volume Productivity to Highly Precise Tooling to a Tooling that is best suited towards low volume production when the volumes are not High we make an attempt to keep the investment cost low that benefits towards the derived product.

**Benefits :** With ECO TOOL you have a product that suites your Low Volume Tablet Production which is again a type of product that every Tableting Facility has but what is not available is a product that can save that unwanted investment that a company has to bear due to the unavailability of such kind of a solution which complies the needs to suit the product cost and unwanted inventory.

**Eligibility :** ECO TOOL is a product developed that can be opted for Products that are Normal to Compress with Low Production Volumes, also while choosing this one has to keep in mind the Product should be Easy or Normal product compatable to Hassle Free Compression than this will prove to be of a Great Financial Benefits resulting in great savings towards the Product.

**Suggestion :** Opting ECO TOOL is a matter of choice for all your Low Volume Products where stocking an inventory is a financial burden for the Company and when such Inventory costs are unaccountable THE ECO TOOL comes in as handy feature for all the Products that need cost monitoring to manage the cost of the end product. With this you know you have made the right choice for the deserved product.





## UNIVERSAL TOOL - THE GLOBAL TOOL.

With THE UNIVERSAL TOOL we have a choice of Tool that is a Global Standard Tool which is a combination of Premium S7 Tool Steel for Punch & D3 / H.C.H.C. Tool Steel for Die and is a combination that is most used worldwide that has the ability to take on all Tableting formulations like a Pro with its ability to take greater compression force and also is a good priced proposition which makes it the favourite to all the general Tablet Compressions, also sticking strong to the standards we are biased towards it for all your general compression needs.

**Benefits :** With UNIVERSAL TOOL you have a product that will be fare to all Compression Products that are categorised as General or Normal to compress and with its greater compression force baring capabilities you have a product that is easy going towards pressure compression also adding to its value badge the product is financially stable and provides value to your purchase.

**Eligibility :** UNIVERSAL TOOL is a product that we tend to standardize as your tool of choice to give you the Best of Both the World as a Great Tool for compression as well as a Great priced proposition which combined makes it a Tool that is used as a Global Favourite for decades and has few products to compete it in Price and Performance.

**Suggestion :** The UNIVERSAL TOOL is a Standard from ROTEK PHARMA TECHNOLOGIES which is proposed for all the General Tableting Requirements and is advised to take in consideration if the Products to be compressed are hassle free and need no extra care.

## SIP (SURFACE IMPROVEMENT PROCESS) - THE PRO TOOL

The SIP TOOL “ The Pro Tool “ is a tool with a Matt Tip Face which is a process oriented development and has been developed mainly to deal with the Formulations that have a low melting point which is just a few degrees near to room temperature and as it goes into compression cycles one cannot stop the heat produced during compression which results in higher temperature increase as the compression speed rises. In such cases the conductivity of the Tool Tip Face matters the most as when the melting happens it results in sticky Tablet Face and to overcome this issue we with a Team of process experts from around the engineering industry have come together and developed a product that is low on conductivity without the addition of any replaceable element.

**Benefits :** With the SIP TOOL we have developed a Tableting Tool that is focused towards resolving the issues that are the most challenging and can result in huge loss of Time and Productivity keeping the Machine engaged for longer than usual disturbing the other compression cycles resulting in irreparable losses for the company, but with the MATT TOOL we ensure a very practical approach dealing with such sensitive products and delivering a end result that is the most satisfactory.

**Eligibility :** The SIP TOOL is eligible and well suited towards the products which are a formulative challenge and have to face the most compression troubles due to its properties. Such products are mainly the Formulations that have relatively low melting points and due to which are restricted to run really slow production cycles to maintain low heat generation during compression.

**Suggestion :** The SIP TOOL is a development that will give you the confidence to go ahead with any compression issue that was a huge challenge in the past, but with this inclusion you are free and unrestricted towards any such product development. This is a Tool that shows our seriousness and efforts stepping towards a hassle free Tableting world.





# TOOL CARE

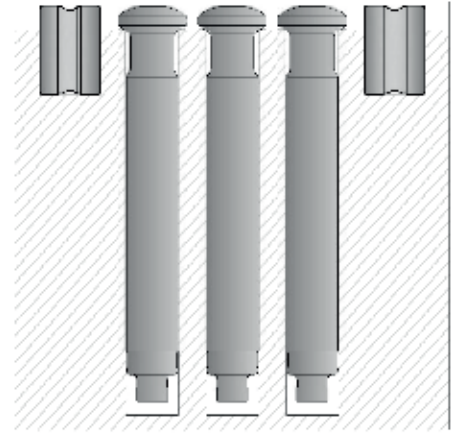
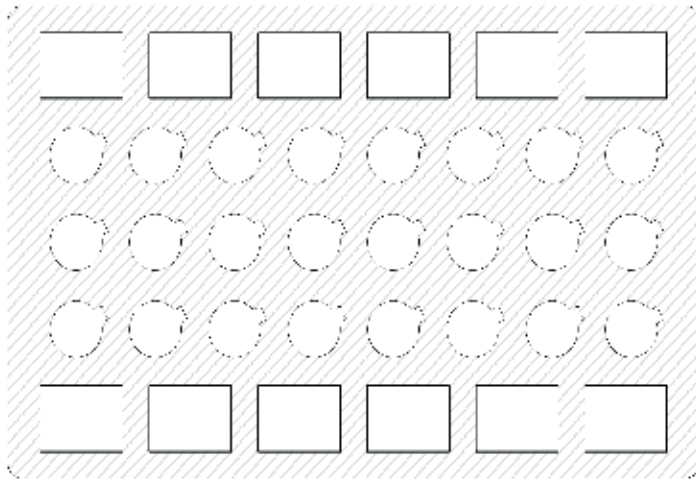

## ROTEK LINEAR PACKAGING

“ The Packaging Hero ”

With the development of ROTEK'S Linear Packaging system we have given a fresh & Commendable approach towards the Packaging of Tablet Compression Tooling's which is one of it's kind and have never been tried by any Tooling Manufacturer ever. With the Linear Packaging system we ensure the best protection of the Tableting Tool within the Compact Dimensions adding Significant weight reduction also minimalizing the use of Recyclable products to ensure Healthier Environment and an approach towards delivering ease of Tool Management.

**Benefits :** With the ROTEK LINEAR PACKAGING we have introduced Vertical Standing Tablet Tool packaging unit which stays within the Tough Recyclable & Reliable Plastic Crate holding the Tablet Punch Tip in Air without letting it touch the base ensuring damage free transit which happens with the support of overhang created with the help of it's Head due to which the Punch stays stable, unmoved and Avoids any contact with one another. Secondly with the Head over the Top it creates a ease of Punch removal without any wrong occurings and providing safety to your Tooling investment. Then there is also a similar approach towards the Die which also stands straight by it's O.D. and also remains Unmoved and Noncontacted with other Dies and also is in ease towards removal of the same which is again unique and is most user friendly. With this we have created a great unboxing experience that is protective at the same time this shows our seriousness towards our Product and our approach to value your investment.

**Eligibility :** The LINEAR PACKAGING system is suitable for all the EU Standard, TSM Standard and other tooling's that have the similar Punch Body, Head and Overall Length of EU or TSM Standard Punch and similar Die O.D. & Height of EU or TSM Standard Die.

A close-up photograph of a metal tool punch, likely used in pharmaceutical tablet production. The punch is cylindrical and has a laser-etched marking on its side. The marking includes the word 'ROTEK' in a stylized font, the year '2019', and the dimensions '2.7mm' and 'Ø14'. The punch is mounted on a metal base with two screws visible on either side.

## ROTEK TOOL MARKING SYSTEM

“ The Informative Tool ”

*A Tool Marking Practice that is a Industry First.*

Tablet Tooling's for most Pharmaceutical Tablet Production Units is an every day approach and a task to maintain and manage the data which becomes difficult to fetch when in need at the batch cycle site, as with the Modern Age Technologies the Compression Machines have become highly intuitive and need a lot of information to be feed to ensure the desired Tableting cycle. Keeping this in mind we have introduced a Tool Marking feature that comes Standard with all the ROTEK Tooling's that accommodates a complete set of information required by the user to feed the Compression Machine and also helps the user to carry on a Tool Inspection process with ease as all the required data is in hand on the Tool to match the Inspection Data that includes Punch Overall Length, Work Length, O.D. , M.O.C. & Coating and Die O.D. , I.D. & Height, also to top this all there is also a Bar Code on the Tools with which one can fetch information like Tablet Layout, Tooling D.Q. and Optional Features added on the Tooling's.

With this ROTEK becomes the industry first to build a Tool that speaks for itself and shares it's own information without any external approach or documentation. With all this we don't stop here as in the race to be the Worlds Best Tablet Tooling Manufacturer we wanted to do something More, something Extra, Something Never Thought of so we add the S.R. No. on the Head Flat of the Punch with this the user can get the direct access to the Punch they need without consuming any time in finding the required and also eases down the process of inspection as they can do it in streamlined manner. This is ROTEK'S way of thanking the user for their Trust shown towards the Brand.



## ROTEK TOOL INSPECTION SYSTEMS

The ROTEK INSPECTION SYSTEMS are full set of equipment's and fixtures required to inspect a Tableting Punch or Die which includes **Manual Inspection & Semi Automatic Inspection**. The Manual Inspection System complies of equipment's that only display the readouts and do not save or bifurcate based on the Data & Tolerances. The Semi Automatic System complies of equipment's that are directly connected to a system that not only reads out dimensions but also saves and bifurcated based on the tolerances set.

### **Manual Inspection System** & Details.

- 1) Sturdy Carry Case with Foam Inlets.
  - 2) Dial Stand.
  - 3) Digital Dial (0.00 to 10.00 mm).
  - 4) Puppet Dial (0.00 to 1.00 mm).
  - 5) Micrometer 0.00 to 25.00 mm (Analogue or Digital).
  - 6) Micrometer 25.00 to 50.00 mm (Analogue or Digital).
  - 7) Radius Gauge 0.10 to 7.00 mm.
  - 8) Radius Gauge 7.50 to 15.00 mm.
  - 9) Radius Gauge 15.50 to 25.00 mm.
  - 10) V Block with C clamp.
  - 11) Punch Standard Overall Length Gauge (EU or TSM).
  - 12) Punch Head Go – NoGo gauge ' B ' Type (EU or TSM).
  - 13) Punch Head Go – NoGo gauge ' D ' Type (EU or TSM).
  - 14) Magnifying Glass (5x Zoom or 10X Zoom or 20X Zoom).
  - 15) Punch Holder ' B ' Type universal.
  - 16) Punch Holder ' D ' type universal.
  - 17) Incremental Dies ' BB ' , ' B ' & ' D ' (Range 0.00 to +0.04 mm).
- Many Options above this which could be opted for as per requirments.

### **Semi Automatic Inspection System** & Details.

- 1) Punch Fixture ' B ' Type adjustable for EU & TSM standard (Tip O.D. , Barrel, Neck & Over all Length).
- 2) Punch Fixture ' D ' Type adjustable for EU & TSM standard (Tip O.D. , Barrel, Neck & Over all Length).
- 3) Punch Work Length Stand and Gauging Instrument.
- 4) Die O.D. , I.D. & Height Fixture and Gauging Instrument.



## ROTEK TOOL POLISHING KIT

**TOOL POLISHING KIT** comprises of Manual Tool Polishing and Automatic Drag Polishing Systems.

The Manual Tool Polishing Kit has a unique Case Design where in one does not have to open the Case or Remove the equipment out of the Carry Case to Polish the Tool Tip as it is designed with 2 Openings One for Inlet & One for Outlet so job process can be concluded without any hassle and provides a user friendly experience, Also the design of it is proprietary and first of its kind.

The **Manual Tool Polishing Kit** comes equipped with :

- 1) Sturdy Carry Case with Foam Inlets.
- 2) 20,000 RPM Pneumatic Motor with RPM control.
- 3) Polishing Brush Holder.
- 4) Tools to open and close the Holder.
- 5) Polishing Paste.
- 6) Polishing Powder.
- 7) Emery Stick.
- 8) Magnifying Eye Glass (5X Zoom or 10X Zoom or 20X Zoom).
- 9) Polishing Brush Set of 5 (Rough & Finish).
- 10) Polishing Paper 5 Nos. (600 grit).

Apart from the above mentioned options all there are many available add on to choose from to suite your requirement.

The **Automatic Drag Polishing System** is as the name suggests a Drag Polishing System which rotates under pressure to create Drag which creates Friction and Friction creates Heat which added to a polishing compound ends up delivering a Shiny Smooth Surface Finish.

The Automatic Drag Polishing System comes equipped with:

- 1) S.S. Panelled Machine with 2 H.P. Geared Motor, Linear Actuator, Fixture Holder 3 Nos. , Compound Drum 35 Kg.
- 2) PLC system for all the on board controls like RPM, Lift, Drop, Timer, Alarm etc.
- 3) Tool Holder Set of 3 (Punch ' B ' 15 Tool , Punch ' D ' 12 Tool, Die Universal 18 Die).
- 4) Polishing Compound Medium 15 Kg.
- 5) Polishing Compound Fine 10 Kg.
- 6) Polishing Paste 15 Kg.

Apart from the above mentioned list of equipment's and options we have a range of options to choose from to suite your requirement.



## ROTEK TOOL CLEANING SYSTEM

TOOL CLEANING SYSTEM is a system based on Ultrasonic Cleaning technology which creates ultrasonic vibrations to create Blasting Bubbles that blast as soon as they come into contact of any surface due to which the cleaning happens to be till the maximum depth of the surface ensuring a Deep and Super Clean Surface free of any foreign residue.

The TOOL CLEANING SYSTEM comes in 4 different stages.

- 1) Single Stage Cleaning (Ultrasonic Cleaning Tank).
- 2) Two Stage Cleaning (Ultrasonic Cleaning Tank & Drying Tank).
- 3) Three Stage Cleaning (Ultrasonic Cleaning Tank, Hot Rinsing Tank & Hot Blow Drying Tank).
- 4) Five Stage Cleaning (Dual Ultrasonic Cleaning Tanks, Dual Hot Rinsing Tanks & Hot Blow Drying Tank).

This are the **4 stages of Ultrasonic Cleaning System** out of which you have a choice to select the best system suitable for your requirement. To make things simpler Below are the Details and suggestions to help you choose better :

**SINGLE STAGE CLEANING** is a System which come with only a Mono Tank for Ultrasonic Cleaning purpose which comes in 2 Models A Tablet Top Model & A Stand Alone Unit. This Single Tank Setup is generally more preferred for Lab Purpose Use and cannot ensure a thorough clean surface.

**TWO STAGE CLEANING** is a System that comes with Ultrasonic Tank & Drying Tank which gives you a Dry Surface after the Ultrasonic dip so to ensure a rust free and near clean surface reducing your cleaning effort and assuring a uniform Dry Clean.

**THREE STAGE CLEANING** is the most popular of all the Ultrasonic Cleaning Systems as is complies of all Three factors required to ensure a Deep Clean, Almost Particle Free & Dry Surface. In which the First Stage is Ultrasonic Cleaning, Second is Hot Rinsing Process to ensure removal of any foreign particle that remains on the external surface of the component and Third is Drying Process, So with the addition of Hot Rinsing Process we can achieve a Maximum Residue Free Surface.

**FIVE STAGE CLEANING** is the Best available solution that is assured to be the Best Surface Free of any unwanted particle. This Five Stages are setup as First Ultrasonic Cleaning, Second Hot Rinsing, Third again Ultrasonic Cleaning, Forth again Hot Rinsing and Fifth Hot Blow Drying, with this combination one can be in complete assurance that the turned out product is Free of any Residue remains and the processed component can be used directly for Compression Cycle with out any further effort.

All the Cleaning Systems come equipped with 2 K.W. quick heater, Punch & Die Holders.



## ROTEK TOOL PRESS SETUP KIT

The TOOL PRESS SETUP KIT has been developed to Maintain and Setup Compression Machine with the use of which one can surely enhance the Shelf Life of the Press and can maintain Burr and Wear Free Press along with a great Time saving during Loading or Unloading of Tooling's.

The **TOOL PRESS SETUP KIT** comes in a carry anywhere case which is light, easy and wobble free case which can be used for multiple Press on the floor depending on availability and need.

The TOOL PRESS SETUP KIT complies of Equipments and Tools required to setup a press which are as follows :

- 1) Carry Case with Foam Inlets.
- 2) Punch Lifter ' B ' Type Universal.
- 3) Punch Lifter ' D ' Type Universal.
- 4) Die Driving Rod ' B ' Type.
- 5) Die Driving Rod ' D ' Type.
- 6) Die Guide Ring ' BB ' Type (Bore Size 24.00 mm).
- 7) Die Guide Ring ' B ' Type (Bore Size 30.16 mm).
- 8) Die Guide Ring ' D ' Type (Bore Size 38.10 mm).
- 9) Die Bore Scraper Ring ' BB ' Type (Bore Size 24.00 mm).
- 10) Die Bore Scraper Ring ' B ' Type (Bore Size 30.16 mm).
- 11) Die Bore Scraper Ring ' D ' Type (Bore Size 38.10 mm).
- 12) Punch & Die Bore Cleaning Brush (Brass).
- 13) Punch & Die Bore Cleaning Brush (Nylon).
- 14) Punch Key Master ' B ' Type.
- 15) Punch Key Master ' D ' Type.
- 16) Torque Wrench with adjustable Pressure.

The above are the list of Tools & Equipments that come as a package, apart from the above stated options we have many more add on to fulfil your requirement.



## ROTEK TOOL STORAGE SYSTEM

TOOL STORAGE SYSTEM is a fabricated S.S. cupboard which stores and protects the Tooling's for any Damages and provides a ease for Inventory Management.

The TOOL STORAGE SYSTEM was developed to keep the Tools Safe from damages and also due to it's S.S. construction also complies to the Pharmaceutical norms, so it can be stored inside the Production facility well within the reach of the user.

TOOL STORAGE SYSTEM comes with **2 types** of setup one is Vertical Storage Type and the Other one is Horizontal Storage Type.

The **VERTICAL Storage Type System** comes with a S.S. Mesh Grid Punch Holder which with the reference of the Punch Head can stay Vertically Hanging in the Holder with out contacting each other but still keeps the contact with the S.S. Mesh Grid Holder which in some cases could cause scratches on the Punch Surface and if not handled with care can also damage the Punch Tip which Removing or Inserting it from the Holder. Secondly the Dies are Stored in a S.S. Basket covered with all the sides only Top Open preventing it from drop or fall, still the Dies in this case Rub with each other which cases scratch on it's contacted Surface and can also cause dents if not handled correctly.

The **HORIZONTAL Storage Type System** comes with a Recyclable Plastic Tray which is covered from all side only Top Open and also keeps the Punches & Dies aligned in the Horizontal Position keeping it's distance from contacting each other due to it's partition design, also as the Tray material is soft it prevents the Tools from any damages. It also comes with a retractable S.S. Handle on Both Sides with S.S. protective plate on the bottom of the Handle to prevent it from cracking in full load.

**Our Recommendation** is HORIZONTAL STORAGE SYSTEM as it is safe and ease to store and handle, also which comes in a wide range options to suite your requirement.

## ROTEK TOOL ACCESSORIES

With ROTEK ACCESSORIES we add to cover up almost all your needs related to the Tableting Tools with which we get you covered for all your requirements and have created a One Stop Solution for all that relates to the Tableting Tools.







SCAN WITH YOUR PHONE  
TO DOWNLOAD E-BROCHURE

## GET IN TOUCH

### HEAD OFFICE

256, Shanti Industrial Estate,  
S.N Road, Mulund (West),  
Mumbai - 400080, INDIA.

+91 9930130101  
+91 7400012660  
+91 7400012661

[info@rotekindia.com](mailto:info@rotekindia.com)

### REGIONAL OFFICE

B-1204, Titanium Heights, Opp. Vodafone  
House, Corporate Road, Prahladnagar,  
Ahmedabad-380051, INDIA.

+91 7400012647  
+91 7400012648  
+91 7400012649

[sales@rotekindia.com](mailto:sales@rotekindia.com)

[WWW.ROTEKINDIA.COM](http://WWW.ROTEKINDIA.COM)